

# D 343/345



# D 343/345

## Dati tecnici

|                      |               |
|----------------------|---------------|
| Anni di costruzione: | 1967 - 1970   |
| Velocità:            | 130 km/h      |
| Rodiggio:            | B' B'         |
| Motore:              | Fiat A218 SSF |
| Potenza oraria:      | 785 kW        |
| Lunghezza:           | 13.240 mm     |

## Cenni storici

Le locomotive D 343/345 sono le prime locomotive diesel-elettriche delle FS, nate affinché si potessero definitivamente abbandonare le locomotive a vapore, quindi utilizzate alla testa di treni merci e viaggiatori, su linee con armamento leggero e non elettrificate.





# D 343/345

## Figurino e quote

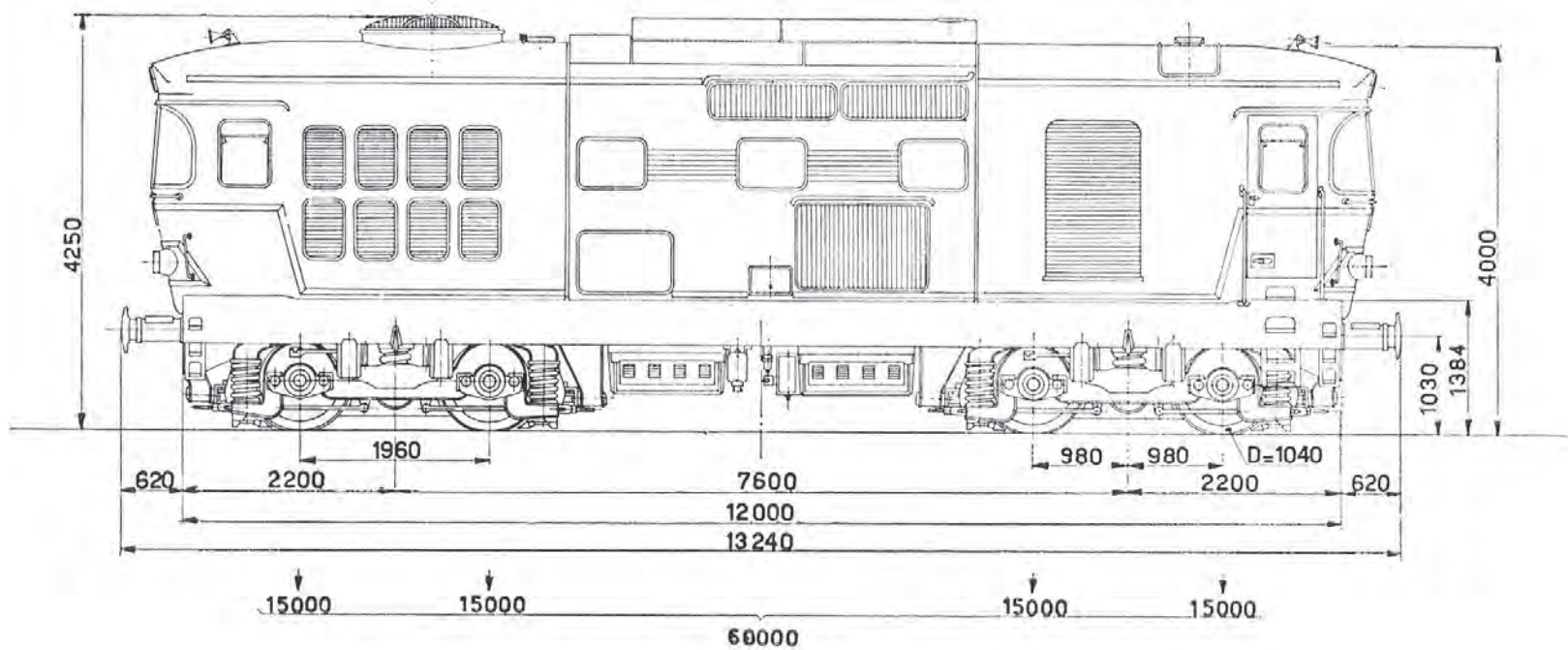

# D 343/345





# D 445



# D 445

## Dati tecnici

|                             |                      |
|-----------------------------|----------------------|
| <b>Anni di costruzione:</b> | 1974 - 1988          |
| <b>Velocità:</b>            | 130 km/h             |
| <b>Rodiggio:</b>            | B' B'                |
| <b>Motore:</b>              | Fiat A2212 SSF       |
| <b>Potenza oraria:</b>      | da 1250 kW a 1560 kW |
| <b>Lunghezza:</b>           | 14.100 mm            |

## Cenni storici

Le D.445 sono le più moderne e potenti locomotive diesel delle FS. Progettate dal 1970 e costruite dal 1974 al 1988 in 150 esemplari suddivisi in tre serie, queste locomotive mantengono l'affidabilità, la versatilità e la buona operatività delle loro predecessori.



# D 445

## Figurino e quote

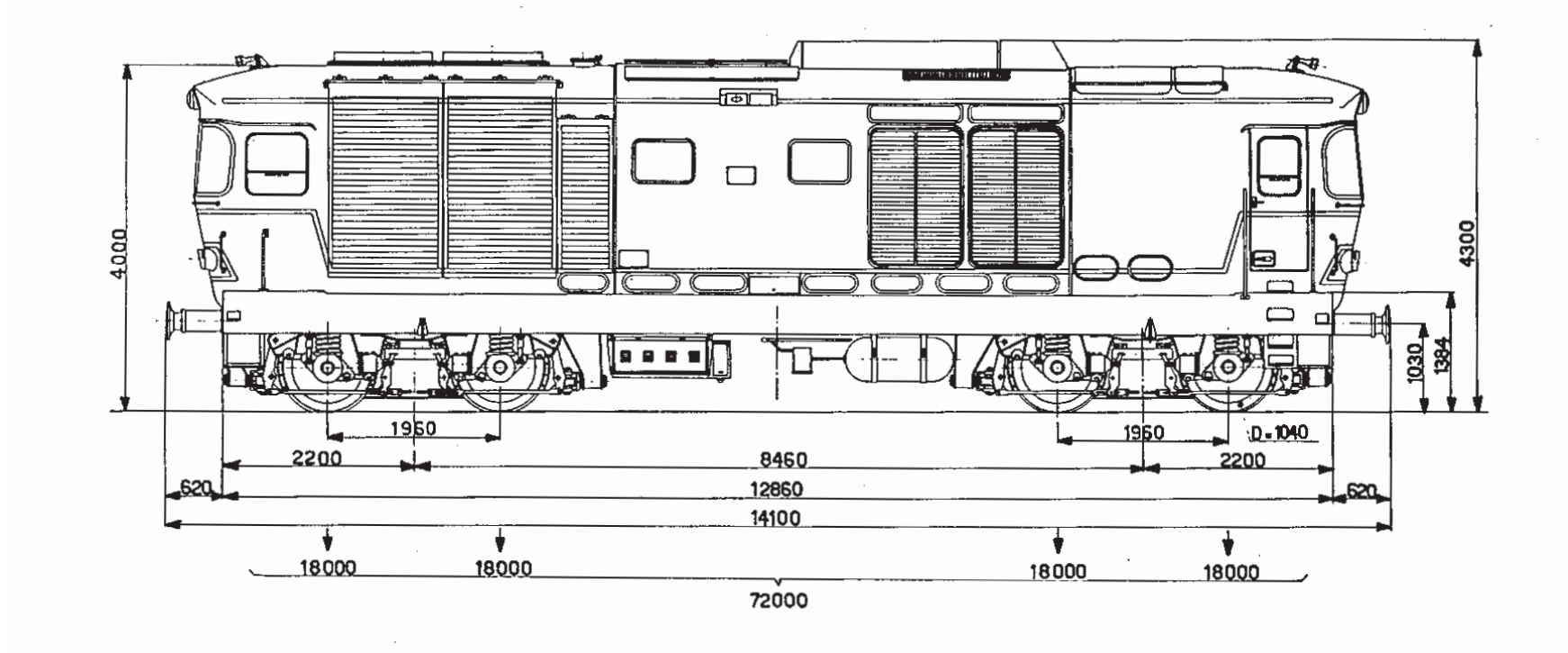



# D 445

